

Project Name:	
Type:	

# (S)RCEL-600 Series

6 & 8 inch LED Exit Sign

## PRODUCT FEATURE

- Suitable for damp location
- Extrusion aluminum alloy trim plate
- 6" or 8" height letter
- Self-test/ self-diagnostics function available
- Remote capability design
- High temperature long life Ni-MH battery
- Acrylic panel changeable design
- Recessed ceiling and recessed wall mount
- Compatible with LynxEM® testing/ reporting system

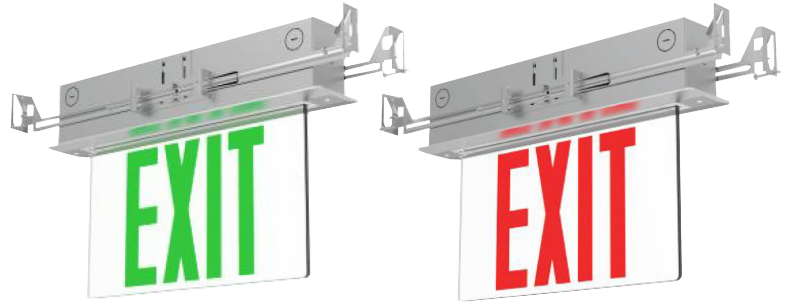

## TECHNICAL SPECIFICATION

Rated Power Supply	: 120/ 277VAC 60Hz
Power Consumption	: Max 2.8W
Charge time	: 24 hours
Discharge duration	: 1.5hour/ 3 hours
Test facility	: Manual test/ Self-test/ LynxEM® testing
Mounting	: Surface wall or ceiling/ Recessed wall or ceiling
LED	: SMD LED
Luminance of safety sign	: Meet UL 924
Ambient temperature	: 5°C - 40°C, Suitable for damp location
Insulation Class	: Class I
Certification	: UL 924

## WARRANTY

- See [Limited Warranty Policy](#) for more additional information

## ORDER INFORMATION:

MODEL	SERIES	FACE	LETTER COLOR	BACKGROUND	TEST FACILITY	REMOTE CAPABILITY	TRIM PLATE FINISHED	PANEL
<b>SCEL</b> Surface mount	<b>600</b> 6" letters	<b>S</b> Single face	<b>R</b> Red	<b>C</b> Clear	<b>Blank</b> MT	<b>RC</b> Max 3.6V 2.8W	<b>AL</b> Aluminum	<b>BLANK</b> Standard Type
<b>RCEL</b> Recessed mount	<b>6000</b> 8" letters	<b>D</b> Double face	<b>G</b> Green	<b>M</b> Mirror	<b>CT</b> CT		<b>WH</b> White	<b>U</b> Single Face + Double Face
					<b>ZD</b> Wireless Reporting LynxEM® Control		<b>BK</b> Black	

## PHOTO



Surface mount (top)



Surface mount (wall)



Full recessed mount (top)



Full recessed mount (wall)

Project Name:	
Type:	

# (S)RCEL-600 Series

6 & 8 inch LED Exit Sign

**DIMENSION :**

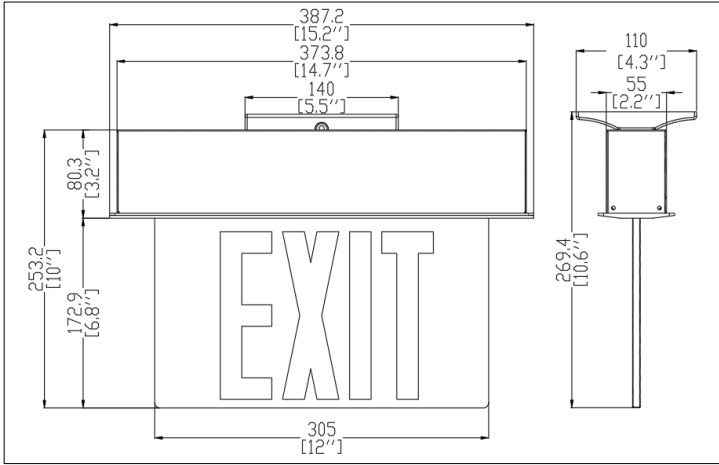

**6" Surface mount (top) size**

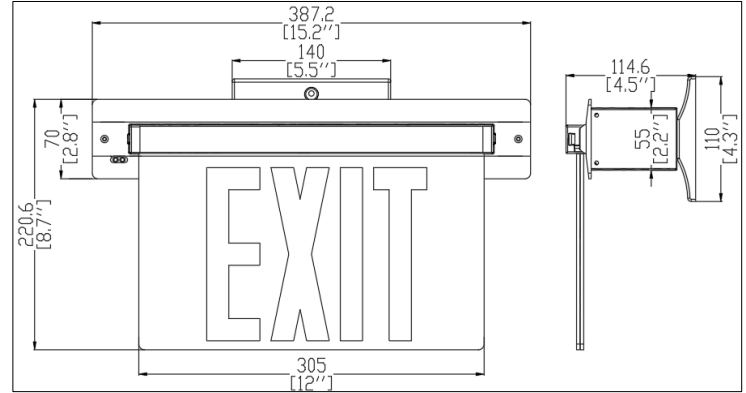

**6" Surface mount (wall) size**

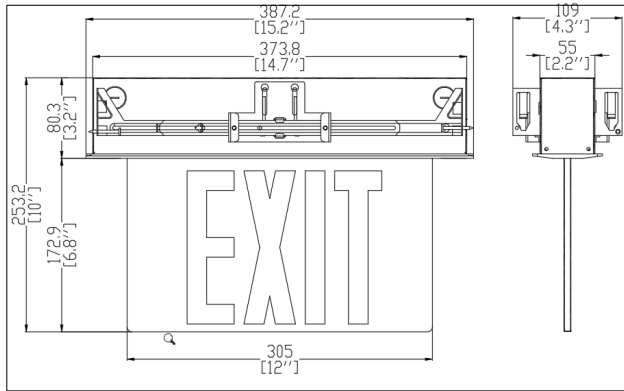

**6" Full recessed mount (top) size**

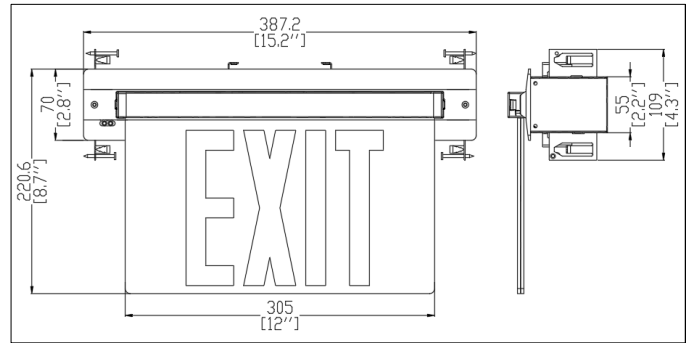

**6" Full recessed mount (wall) size**

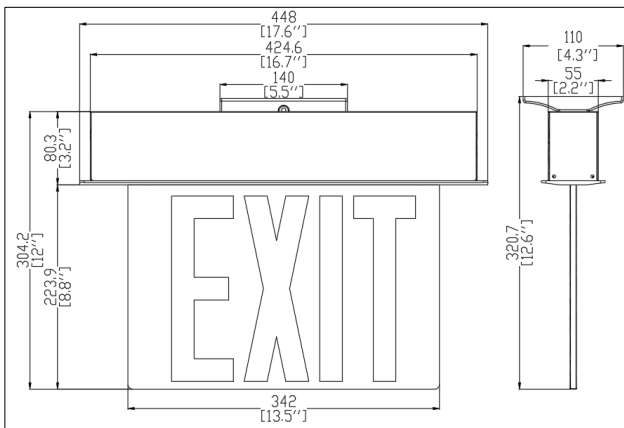

**8" Surface mount (top) size**

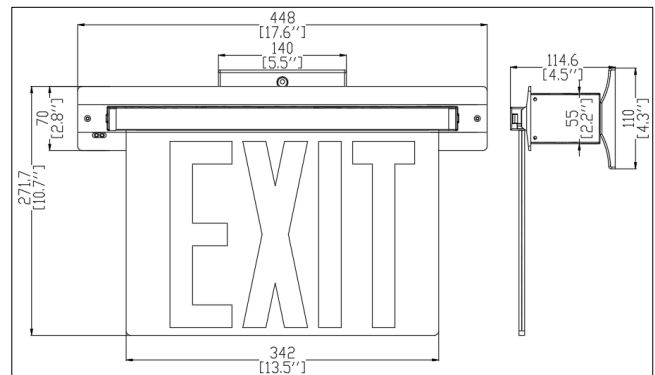

**8" Surface mount (wall) size**

Project Name:	
Type:	

# (S)RCEL-600 Series

6 & 8 inch LED Exit Sign

## DIMENSION :

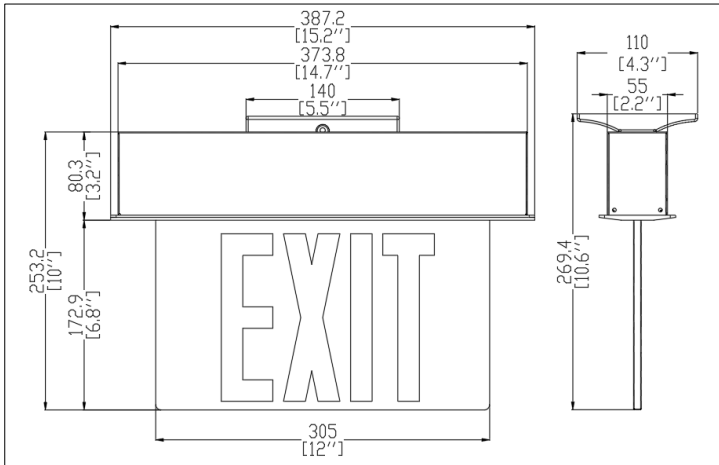

**6" Surface mount (top) size**

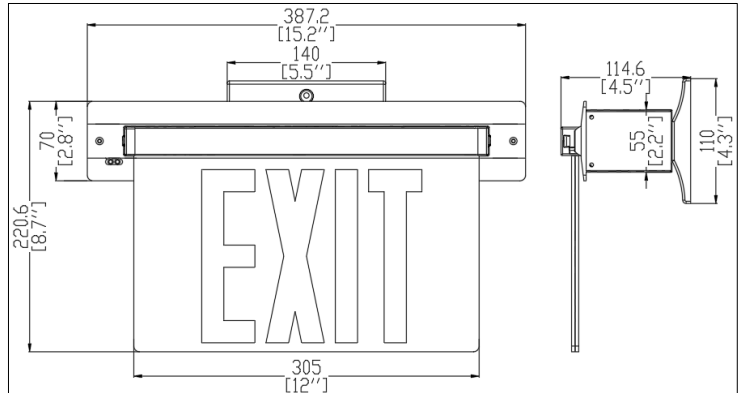

**6" Surface mount (wall) size**

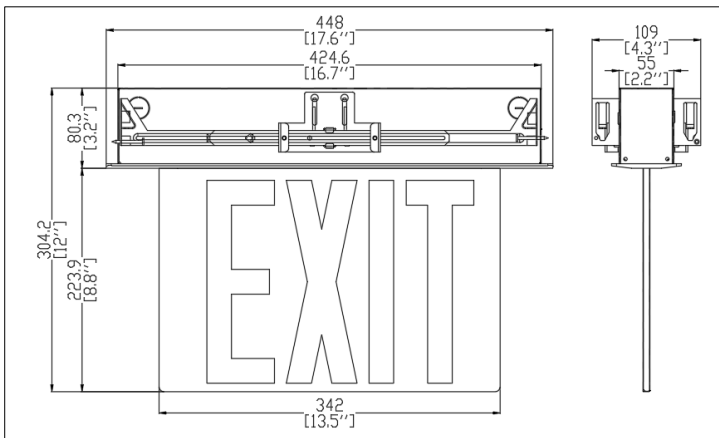

**8" Full recessed mount (top) size**

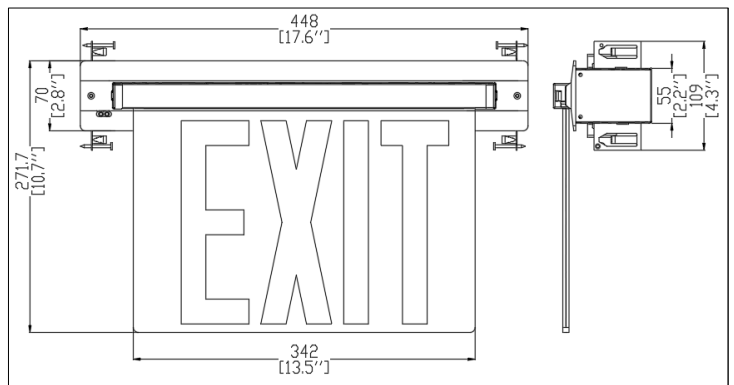

**8" Full recessed mount (wall) size**

## PRODUCT INSTALLATION GUIDE :

Step1: Install canopy to junction box

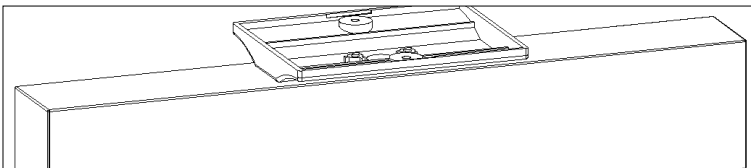

Step2: Wiring AC lead to outlet box, fixed the unit to outlet box

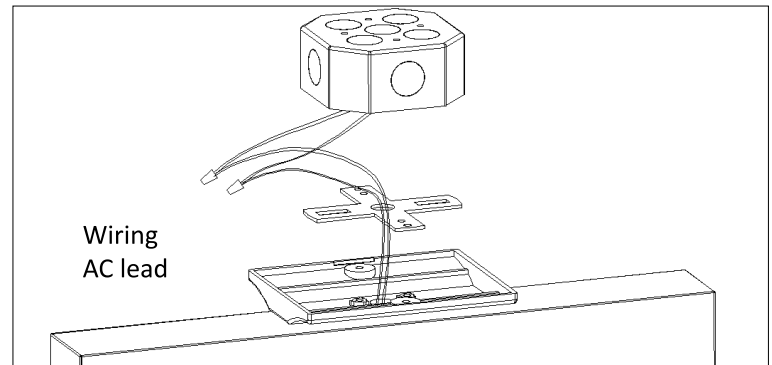

Project Name:	
Type:	

# (S)RCEL-600 Series

6 & 8 inch LED Exit Sign

## PRODUCT INSTALLATION GUIDE :

Step3: Separate trim module and connect battery connector to PCBA

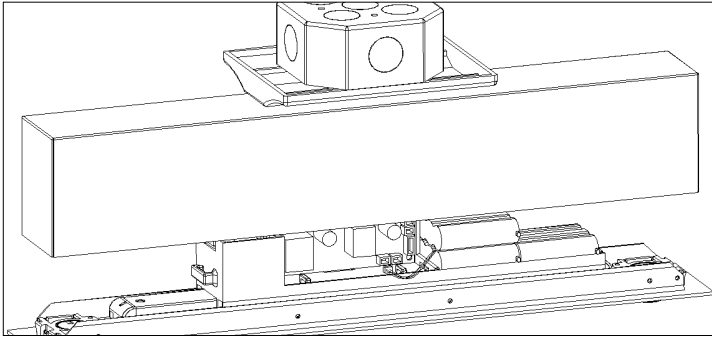

Step4: Push the unit back to the junction box, assembly panel module

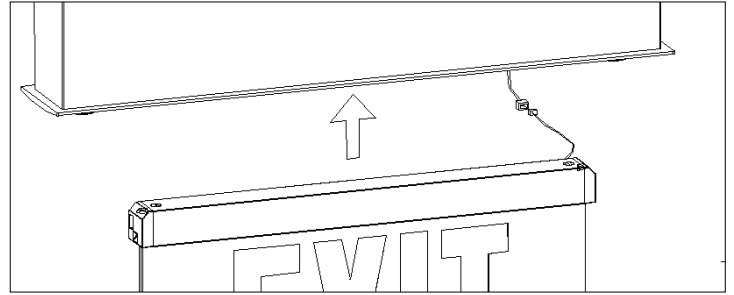

## PACKAGING

### SCEL-600 & RCEL-600

INNER BOX: 415 x 220 x 112mm  
 CARTON BOX: 430 x 445 x 245mm  
 Q'TY: 4PCS  
 N.W: 8.5KGS  
 G.W: 10.5KGS  
 MEA'S: 1.7 CUFT

### SCEL-6000 & RCEL-6000

INNER BOX: 475 x 260 x 110mm  
 CARTON BOX: 535 x 490 x 240mm  
 Q'TY: 4PCS  
 N.W: 10.0KGS  
 G.W: 12KGS  
 MEA'S: 2.2 CUFT

