

Project Name:	
Type:	

WTC-001 Wireless Test Controller for Maintained Emergency Lighting Fixture

For Emergency Egress Lighting Testing and Reporting

This innovative and multi-function wireless test controller is designed to test the always-on emergency egress lighting in compliance with the NFPA101 Life and Safety code. While we understand the complexity and labor involvement of such tasks, the WTC-001 will help alleviate the colossal of daily workload to deliver the needed results without any deviations from the NFPA101 requirements. This will save you plenty of free time to work on other critical tasks.

This ETL-certified wireless test controller is easily installed in the existing fixtures between the normal/emergency AC line feed and the power supply of the lighting fixture. Once commissioned to the LynxEM® system, it will continuously monitor the device status at all times. The WTC-001 can report the failure in real time as soon as an abnormal status is detected. A monthly and yearly testing can also be conducted based on set schedules to comply with the basic codes and the results will be delivered instantly for your disposal. It is no longer required to walk around the facility to manually trigger the testing one at a time. The result is not only saving the operational cost, it has tremendous savings with regular maintenance costs as well. Most importantly, all of the emergency egress lighting is ensured functional during the emergency or abnormal situation.



WARRANTY

- See [Limited Warranty Policy](#) for more additional information.

SPECIFICATIONS :

	Test Controller	
MODEL NUMBER	WTC-001T	WTC-001N
COMPATIBILITY	LynxEM®	
INPUT	110 – 277VAC/ 50 – 60Hz	
OUTPUT VIA ISOLATED REPLY	110 – 277VAC/ 50 – 60Hz, 10 Amps Max.	
OPERATING ENVIRONMENT	-20 to +65°C	
RADIO PROPERTIES	2.4GHz, +19.5dBm Transmit Power	
ANTENNA	Built-in or External	Built-in
EXTERNAL ANTENNA	Optional with connector	N/A
DIMENSIONS	123.3 x 39 x 29mm (L x W x H)	87 x 58 x 48mm (L x W x H)
COMPLIANCE	ETL/ FCC Certified	Pending
WARRANTY	5 YEAR	
CONNECTIONS	Terminal block	½" NPT

MODEL SELECTION :

WTC-001T	Design with terminal block for wiring
WTC-001N	Design with ½" NPT for junction box wiring

WIRING DIAGRAM :

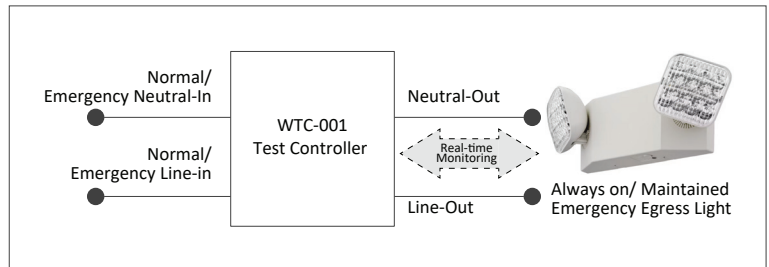

MECHANICAL DRAWING :

WTC-001T:

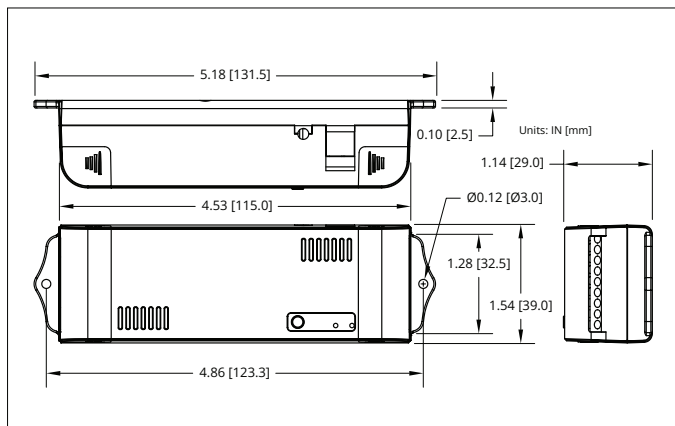

WTC-001N:

