

# EX-800 Series

LED Exit Sign  
Egress Lighting and Wireless Egress Lighting



## PRODUCT FEATURE

### HOUSING

- Injection-molded thermoplastic ABS housing.
- Plastic enclosure with 5VA flame retardant.
- Replaceable directional chevron insert are
- Red or green letter with 6 " height and 3/4" stroke.
- Single and double face configuration.
- LynxEM® Wireless Testing and Reporting System

### ELECTRICAL

- 120/277VAC Dual voltage operation
- 220-240VAC model optional
- Test switch and charge rate indicator
- Long-life maintenance free, rechargeable Ni-cad battery
- 24 hours recharge after 90 minutes discharge

### LISTING

- Suitable for use in 10°C - 40°C ambient temperature, suitable for damp location
- UL and CSA listed according standard UL924 and CSA C22 2 NO 141-10
- Meets or exceed all requirement in NFPA 70, NFPA 101 life safety code
- Compliant CEC title 20 efficiency regulations

### ILLUMINATION

- 6 red or green LED mount on LED PCBA
- Unit provide not less than 8.6cd/mm<sup>2</sup> on AC and DC mode

### MOUNTING

- Suitable for wall mounting, ceiling mounting and side mounting
- Housing snaps to canopy with simple twist and locking tightly secure housing to canopy

### RELATED PRODUCTS

- [S1 Series Exit Sign](#)
- [S2 Series Exit Sign](#)
- [S3 Series Exit Sign](#)
- [CB-810 Exit Combo](#)

### WARRANTY

- See [Limited Warranty Policy](#) for more additional information

## ORDER INFORMATION: *EXAMPLE: EX-810T-GX-3H-CT-B-3*

EX	-	-	-	-	-	-						
MODEL	CIRCUIT		LETTER COLOR		DISCHARGE DURATION		TEST FACILITY		HOUSING COLOR		VOLTAGE	
EX	<b>800</b>	Battery backup	<b>RX</b>	Red	<b>BLANK</b>	Manual test	<b>BLANK</b>	Manual test	<b>W</b>	White	<b>1</b>	120/277V
	<b>810</b>	AC only	<b>GX</b>	Green	<b>3H</b>	3 hours (Only for GX manual test)	<b>CT</b>	Self-testing/ Self-diagnostics	<b>B</b>	Black	<b>3</b>	220-240V (green color)
	<b>810T</b>	Dual circuit – AC/AC					<b>ZD</b>	Wireless Reporting LynxEM® Control				

Project Name:	
Type:	

# EX-800 Series

LED Exit Sign  
Egress Lighting and Wireless Egress Lighting

## PRODUCT DIMENSION

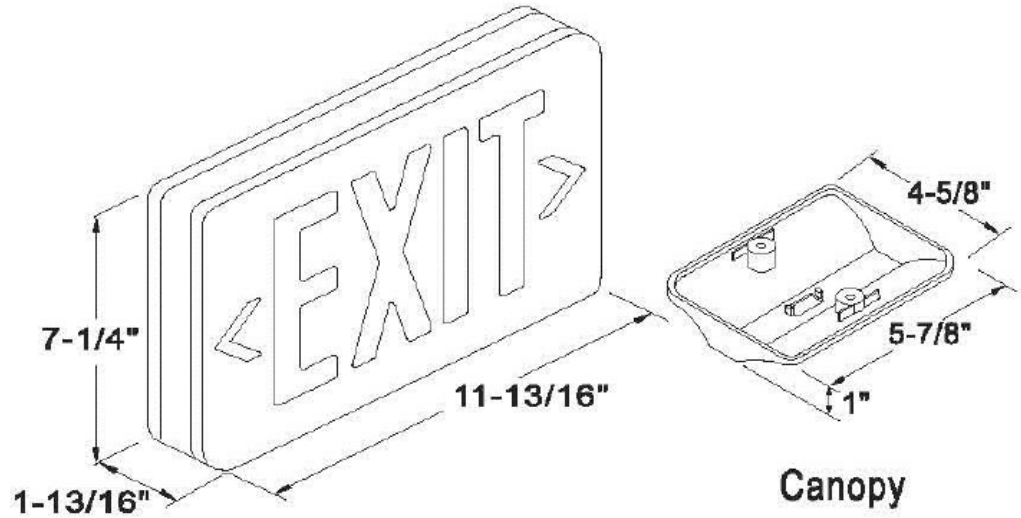

## PACKAGING

Q'TY	:	12 PCS
N.W	:	12.5 KGS
G.W	:	14.5 KGS
MEA'S	:	1.84 CUFT

**NOTE:**

Universal package contained assembled 2 exit panel and one back plate for backup

