

Project Name:	
Type:	

# MCA(B)-105 Series

105 Outdoor Driver

## PRODUCT FEATURE

- Input voltage range: 90–305 Vac;
- Constant power design, outputs programmable;
- Adjustable output current by software
- Multiple dimming capability (P types): 0/1–10Vdc / PWM / Step time dimming;
- Dim to Off
- Surge protection: 5KV line-line, 10KV line-earth;
- Protections: SCP / OVP / OTP;
- IP67 design for indoor and outdoor applications;
- Suitable for dry / damp / wet locations;
- 5 years warranty



Notes : MCA-105 is Class I type, MCB-105 is Class II type

## APPLICATION

Street Lighting, architecture lighting, industrial lighting, flood lighting, etc.

## WARRANTY

- See [Limited Warranty Policy](#) for more additional information

## MODEL ENCODING

**M C A - 105 - 062 XY**  
① ② ③ ④ ⑤ ⑥

SERIAL NUMBER	ITEM	DEFINITION
①	Structure	<b>M:</b> Metal case <b>P:</b> Plastic case <b>O:</b> Open frame  (It can add module power supply, iron shell power supply, and etc.)
②	Type	<b>C:</b> Constant current <b>V:</b> Constant voltage <b>P:</b> Constant current & constant voltage  (Other specifications can be defined later, such as <b>I:</b> Industrial power supply, <b>R:</b> Rainproof power supply, <b>S:</b> Customized power supply, etc.)
③	Series Name	<b>A:</b> Class I <b>B:</b> Class II
④	Rated Wattage	3 to 4 digits (such as 105 means 105W)
⑤	Output Voltage	Maximum voltage
⑥	Dimming	<b>X (N):</b> No dimming, <b>D :</b> Wire dimming: 0/1-10V/ PWM, <b>P :</b> Programmable with wire dimming and time step dimming, <b>Y (Y=0-1.2v</b> auxiliary power supply)

DIMMING	FUNCTION	NOTES
P	Programmable with wire dimming and time step dimming	On stock
P12	Programmable with wire dimming and time step dimming, 12v auxiliary power supply	
N	No dimming and programmable function	

Project Name:	
Type:	

# MCA(B)-105 Series

105W Outdoor Driver

SPECIFICATION					
MODEL		41	62	100	150
MCA(B)-105-XXXN					
INPUT	Efficiency (230Vac)(Typ.)	90%	91%	91%	92%
	Voltage Range (V)	90~305VAC, or 127 ~ 430VDC			
	Rated Voltage (V)	100~277VAC			
	Frequency Range (Hz)	47~63			
	Power Factor	PF>0.97/120VAC, PF>0.95/230VAC, PF>0.92/277VAC at full load			
	THD	THD<10% when output loading $\geq$ 50% at 120VAC/230VAC THD<15% when output loading $\geq$ 50% at 50VAC/277VAC (Take refer to THD vs. Load Curve for details)			
	AC Current (Max.)	1.5A MAX at 120Vac, 0.7A MAX at 230Vac			
	Inrush Current (Max.)	COLD START 75A (twidh=350 $\mu$ s measured at 50% Ipeak) at 230VAC, Per NEMA410			
	Leakage Current (Max.)	0.75mA at 277Vac/60Hz			
	MAX. No. of PSUs on 16A Circuit Breaker	3 units (circuit breaker of type B) / 6 units breaker of type C) at 230VAC			
	No Load/ Standby Power Consumption	No load power consumption <6/ Standby Power Consumption <0.5W			
OUTPUT	Rated Output Voltage (V)	30 – 41	42 – 62	75 – 100	100 – 150
	Output Voltage Range (V)	20 – 41	38 – 62	50 – 100	75 – 150
	Rated Current (A)	2.56 – 3.50	1.69 – 2.50	1.05 – 1.40	0.70 – 1.05
	Rated Power (W)	105	105	105	105
	Output Current Setting Range/ Dimming Range (A)	0.35 – 3.50	0.25 – 2.50	0.14 – 1.40	0.11 – 1.05
	Constant Power Setting Range (A)	2.56 – 3.50	1.69 – 2.50	1.05 – 1.40	0.70 – 1.05
	Ripple Current (Typ.)	5% of Io_max. ((PK-AV) /AV) with LED loading mode and full load.)			
	Current Tolerance	<5%			
	Line Regulation	<1%			
	Load Regulation	<3%			
	Setup Time	<2s, at 120Vac; <0.5s, at 230Vac			
	DC AUX Power (P12 Type)	5V/12V/24V Selectable; Max Output Current: 200mA; Output Voltage Tolerance: $\pm$ 10%; Max Output Power: 0.36W			
	Dim to Off	18V Max	25V Max	41V Max	53V Max
	DIM+ Short/ Source Current	Yes, but need to take refer to the above turn-off voltage 150uA~350uA			
PROTECTION	Short Circuit Protect (SCP)	Hiccup mode, recover automatically with short circuit removed.			
	Over Voltage Protect (OVP)	Voltage limiting. Output current is decreased if the required loading voltage is higher than MAX. output voltage.			
	Over Temperature Protect (OTP)	Decrease the output current, but not less than 20% of rated output current, recover automatically once the fault condition is removed.			
ENVIRONMENTAL	Working Temperature	-40~+60°C( Refer to 'Derating Curve' )			
	Max. Case Temperature (Tc)	90°C max			
	Working Humidity	20~95%RH			
	Storage Temp., Humidity	-40~+85°C, 10~95%RH			
	Vibration	10-500Hz, 5G 12min/cycle, period for 72min each along X、Y、Z axes			

# MCA(B)-105 Series

105W Outdoor Driver

<b>SAFETY &amp; EMC</b>	Safety Standard	UL8750, CSA C22.2 No. 250.13-12; ENEC EN61347-1, EN61347-2-13 independent, EN62384; GB19510.1,GB19510.14
	Withstand Voltage	I/P-O/P: 3.75kVac, I/P-FG:1.65kVac, O/P-FG:1.5kVac
	Isolation Resistance	I/P-O/P, I/P-FG, O/P-FG: 100M Ohms (500VDC / 25°C/ 70% RH)
	EMC Emission	FCC Part 15 Class B/ EN55015, EN61000-3-2 Class C, EN61000-3-3
	EMC Immunity	EN61000-4-2,3,4,5,6,8,11, EN61547 (Surge: L-N: ±5kV, L,N-FG: ±10kV)
<b>OTHERS</b>	MTBF	200000Hrs @25°C±10°C ambient temperature, 230Vac, 80% load (MIL-HDBK-217F)
	Lifetime	50000Hrs@80°C case temperature (Refer to 'Lifetime Curve')
	Dimension	154 x 66.2 x 36.8mm (LxWxH)
	Weight (Typ.)	700±50g/ PCS
<b>RELIABILITY</b>	Screen test <sup>(1)</sup>	336Hrs aging test @95°C & full load without temperature protection
Notes:		
1. The test results are based on 14 samples with OTP moved		
2. All the data are measured under room temperature if not specified.		

## OPERATING AREA I-V

Notes: X=N is suitable for the right area of the dotted line; X=P is suitable for the solid line contain area.

**MCA(B)-105-041XY**

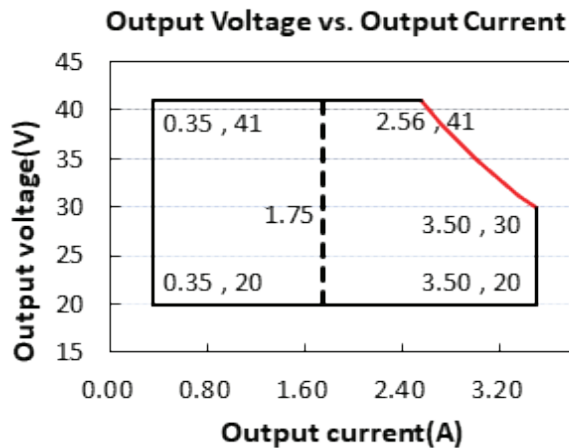

**MCA(B)-105-062XY**

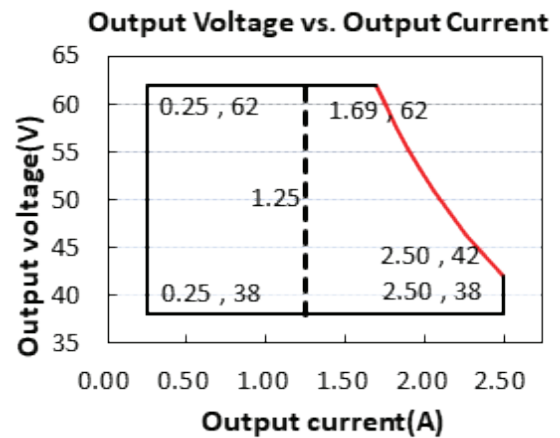

**MCA(B)-105-100XY**

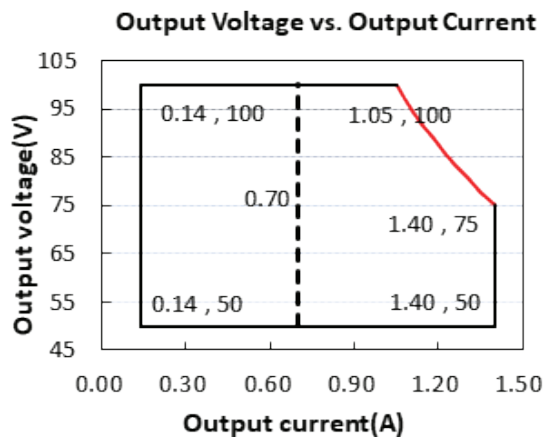

**MCA(B)-105-150XY**

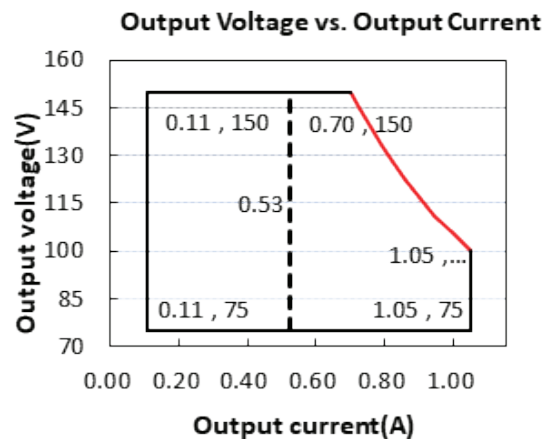

Project Name:	
Type:	

# MCA(B)-105 Series

105W Outdoor Driver

## INRUSH CURRENT WAVEFORM

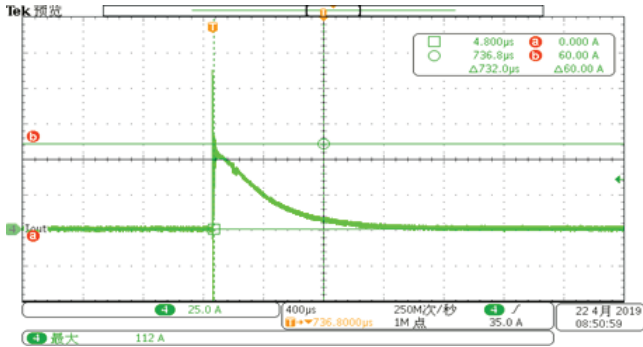

## DERATING CURVE

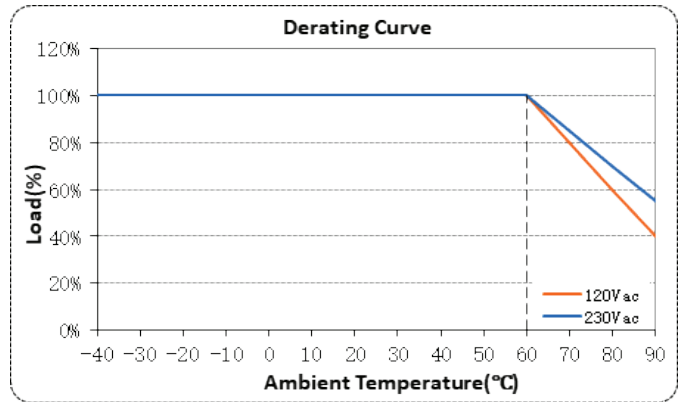

## OUTPUT POWER VS INPUT VOLTAGE

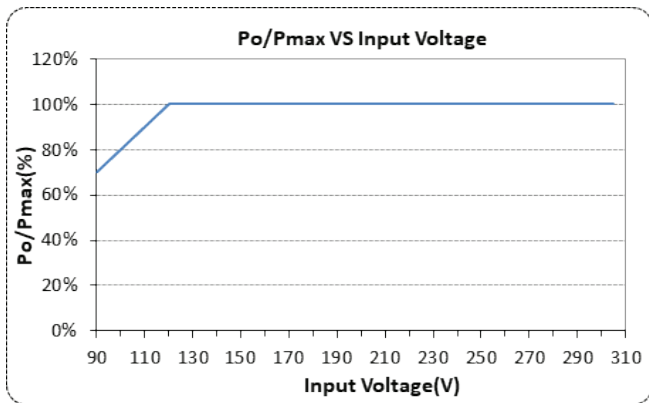

## LIFETIME VS CASE TEMPERATURE

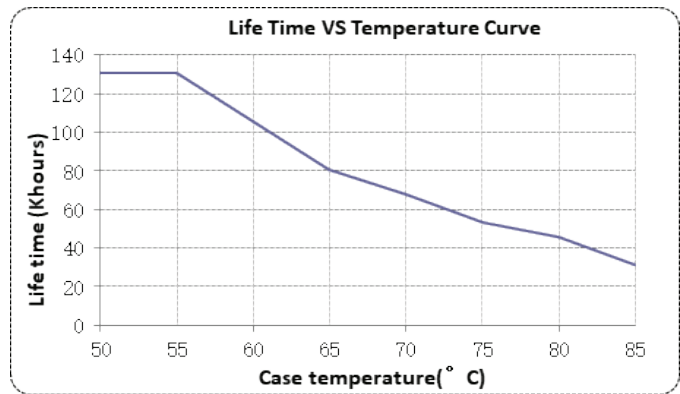

## INSTRUCTION

MCA(B)-105-041XY (Uo=36V)

### Efficiency VS Load

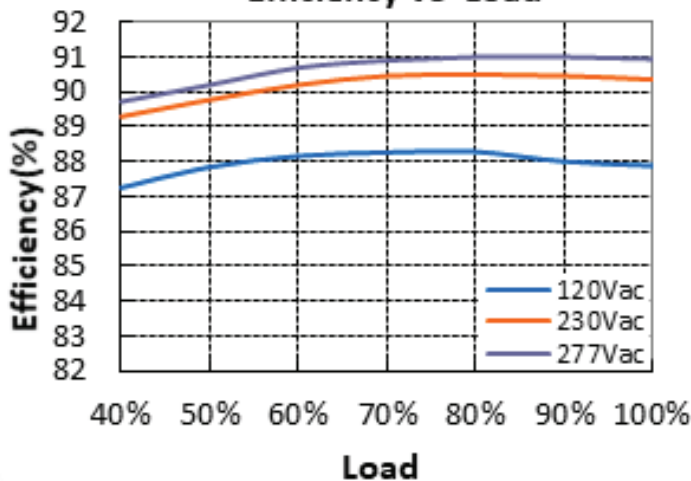

MCA(B)-105-062XY (Uo=48V)

### Efficiency VS Load

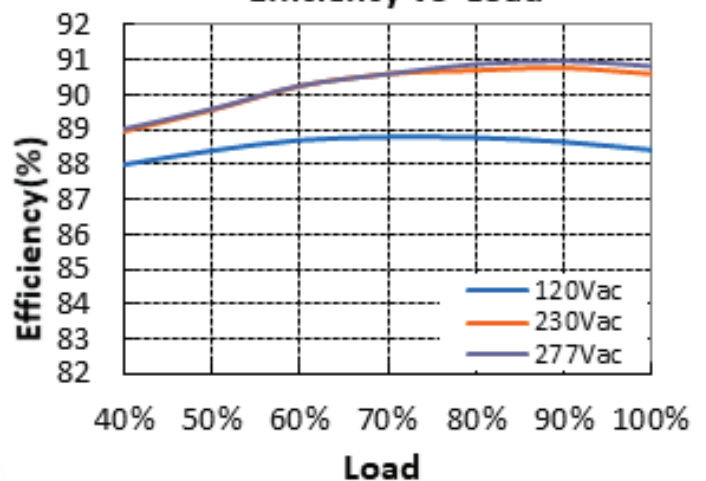

Project Name:	
Type:	

# MCA(B)-105 Series

105W Outdoor Driver

**MCA(B)-105-100XY(Io=1.05A)**

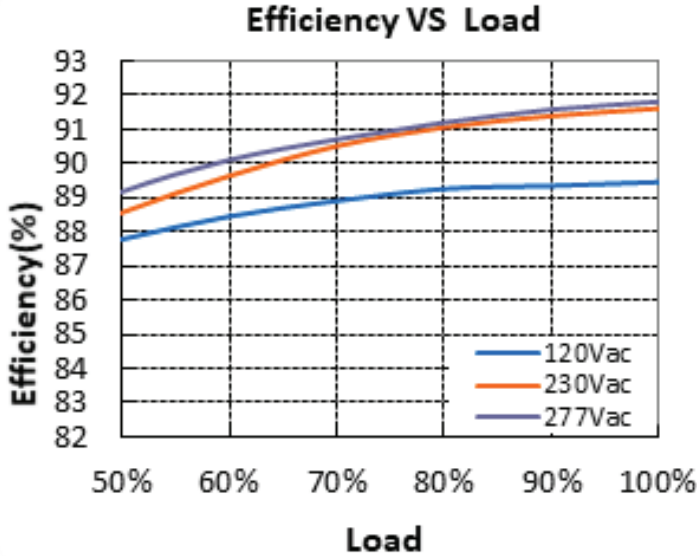

**MCA(B)-105-150XY(Io=0.7A)**

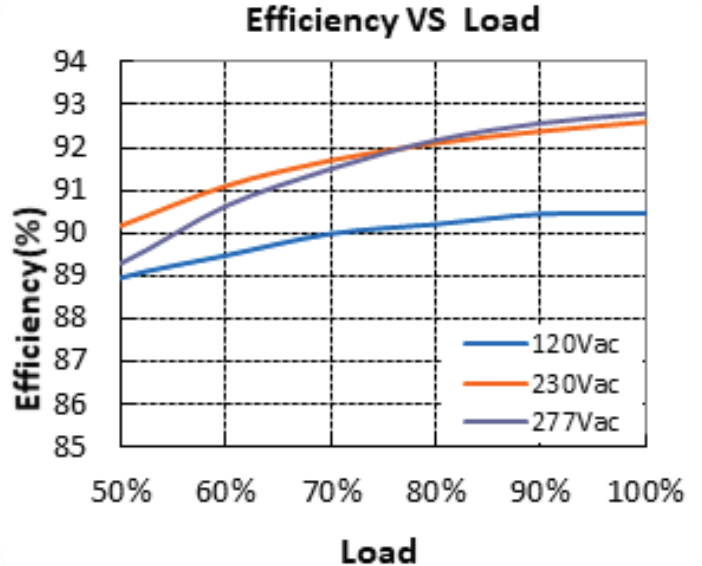

**POWER FACTOR VS LOAD**

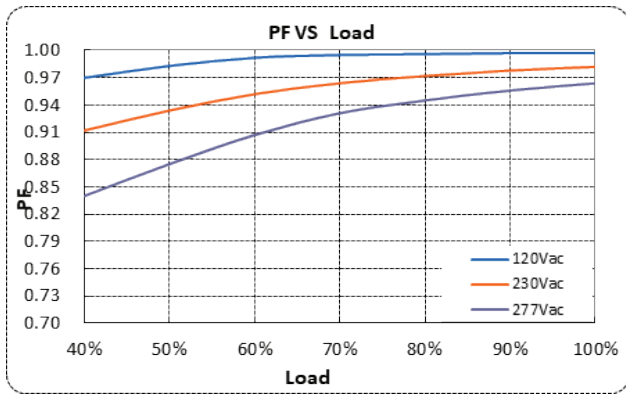

**TOTAL HARMONIC DISTORTION**

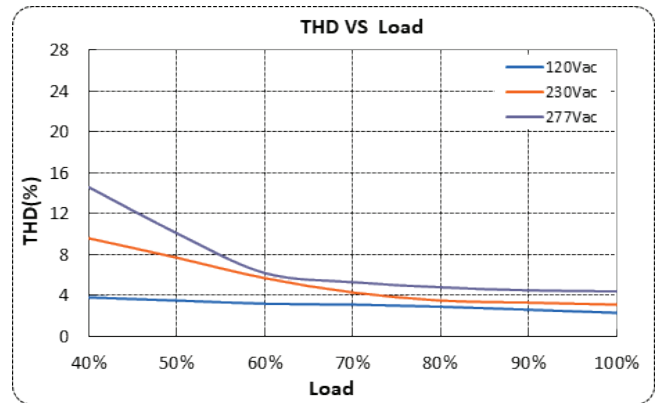

**INSTRUCTION**

1. Field Programmable Topology.

The programmable driver can be programmed by using special PC software and the programmer module.

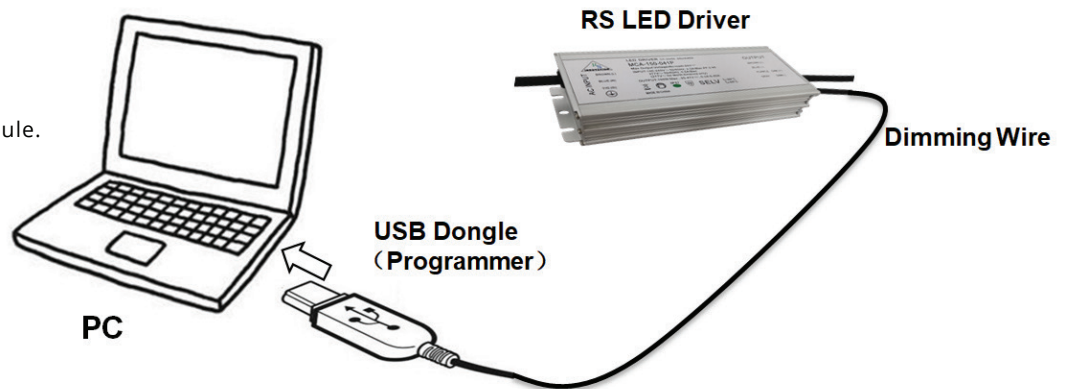

Project Name:	
Type:	

# MCA(B)-105 Series

105W Outdoor Driver

## Dimming Interface Description

Pin description

PIN	NAME	VALUE	DESCRIPTION	COLORS
1	Vaux 12V+	10.8V-13.2V	Auxiliary DC power supply	WHT/BLK
2	Dim+/Prog+	0-10V	Dimming/Programming input	PURPLE
3	Dim-/Com	0V	Common terminal of Dim/Prog./Aux	GRAY

### 3. Dimming Software Function Instruction

#### • Communication Setup



Click "Connect" to set up the link between the computer and the USB dongle.

#### • Driver Identification



Click "Read" to identify the driver, then fill in the part number and max current automatically.

#### • Adjustable Output Current (AOC)



Click ON  to activate the output current configuration, I. Max(Spec) is filled in automatically during identify driver, I. Set can be filled in any value lower than I. Max(spec).

#### • Dimming Selection and Setting



Click ON  to activate the dimming selection and setting, or else no update during current setting. Choose one of the control method listed below to go with, then the related setting interface will appear.

#### • Turn-Off signal setting

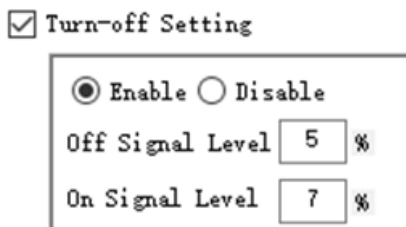

Click ON  to activate the turn-off function configuration. Choose "enable" or "disable", and set the turn on and off dimming signal when "enable" selected. In turn off status, the driver will output minimum output voltage, please make sure the LED lamp can be turned off when applied with this level voltage.

#### • Dimming Logic

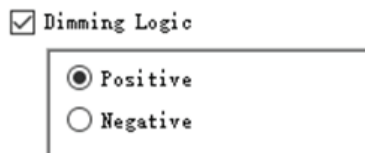

Click ON  to activate the dimming logic configuration, default setting is "Positive" logic, it means the output current will increase with the dimming signal level up; and "Negative" logic will decrease the output current with dimming signal level up.



Project Name:	
Type:	

# MCA(B)-105 Series

105W Outdoor Driver

## • Set Minimum Dimming Level

Set Min. Dimming Level

Min. Dimming Level  %

Set the minimum dimming output current, default setting is 10%

## • Dimming Signal Configuration

Configure Dimming Signal

Signal Voltage setting:

Compliant with analog and PWM signal:  
 1) Analog: 0-10V  
 2) PWM: Low level-0V, High Level-10V

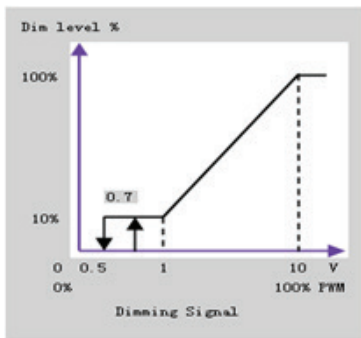

Click ON "" to activate dimming signal configuration, the dimming signal can be analog or PWM signal, here to set the value of the high level of these two signals, the setting can be:

0-3.3V, 0-5V, 0-9V, 0-10V

For example, if 0-10V is selected, the dimming signal will be:

- 1.) Analog: 0-10V.
- 2.) PWM: Low level-0V, High Level-10V.

This graph presents how the output current will react to the dimming signal, including analog and PWM dimming signal.

## • Configure Time Step Dimming (TSD)

Configure Time Step Dimming

(0)	<input checked="" type="checkbox"/>	<input type="text" value="10"/>	Second(Soft Start)	
		Hour	Minute	Power
(1)	<input checked="" type="checkbox"/>	<input type="text" value="4"/>	<input type="text" value="0"/>	<input type="text" value="100"/> %
(2)	<input checked="" type="checkbox"/>	<input type="text" value="1"/>	<input type="text" value="0"/>	<input type="text" value="80"/> %
(3)	<input checked="" type="checkbox"/>	<input type="text" value="2"/>	<input type="text" value="0"/>	<input type="text" value="60"/> %
(4)	<input checked="" type="checkbox"/>	<input type="text" value="1"/>	<input type="text" value="0"/>	<input type="text" value="80"/> %
(5)	<input checked="" type="checkbox"/>	<input type="text" value="3"/>	<input type="text" value="0"/>	<input type="text" value="100"/> %
(6)	<input type="checkbox"/>	<input type="text" value="0"/>	<input type="text" value="0"/>	<input type="text" value="10"/> %
(7)	<input type="checkbox"/>	<input type="text" value="0"/>	<input type="text" value="0"/>	<input type="text" value="10"/> %

Click ON "" to activate Time Step Dimming configuration

Step(0): Setting the fading time of soft start, maximum value can be 10 seconds.

Step (1)-(7): Maximum time step number is 7, and the output current can be set according to the customer requirements to save energy.





Project Name:	
Type:	

# MCA(B)-105 Series

105W Outdoor Driver

## MECHANICAL OUTLINE

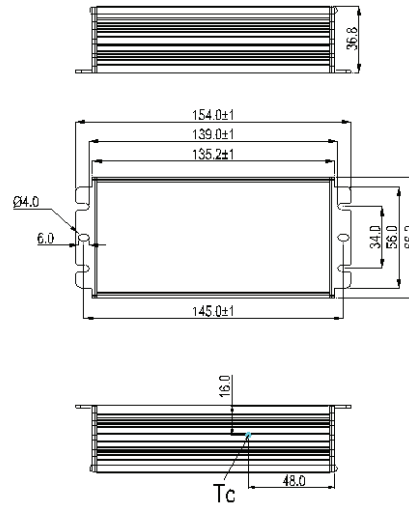
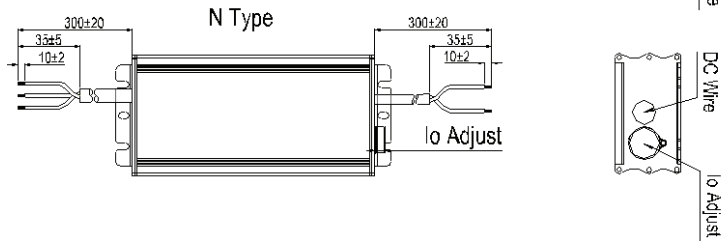
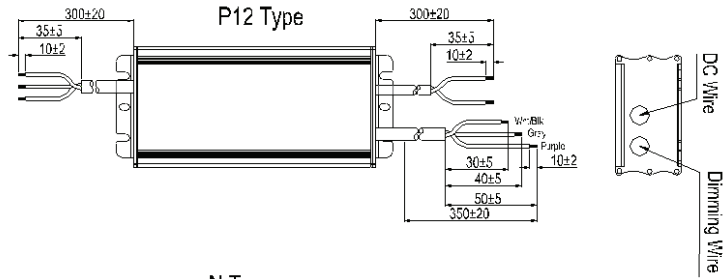
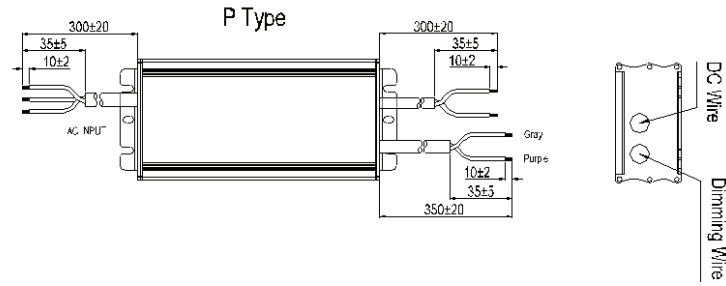

WIRE	SPECIFICATION	NOTE
Input	CCC+VDE H05RN-F 3*1.0mm <sup>2</sup> L=300mm	for CE
	18AWG*3C SJOW L=300mm	for UL
Output	CCC+VDE H05RN-F 2*1.0mm <sup>2</sup> L=300mm	for CE
	18AWG*2C SJOW L=300mm	for UL
Dimming	22AWG*2C UL2733 L=350mm	for P
	22AWG*3C UL21996 L=350mm	for P12
Input	CCC+VDE H05RN-F 3*1.0mm <sup>2</sup> L=300mm	for CE
	18AWG*3C SJOW L=300mm	for UL

Project Name:	
Type:	

# MCA(B)-105 Series

105W Outdoor Driver

## MECHANICAL OUTLINE

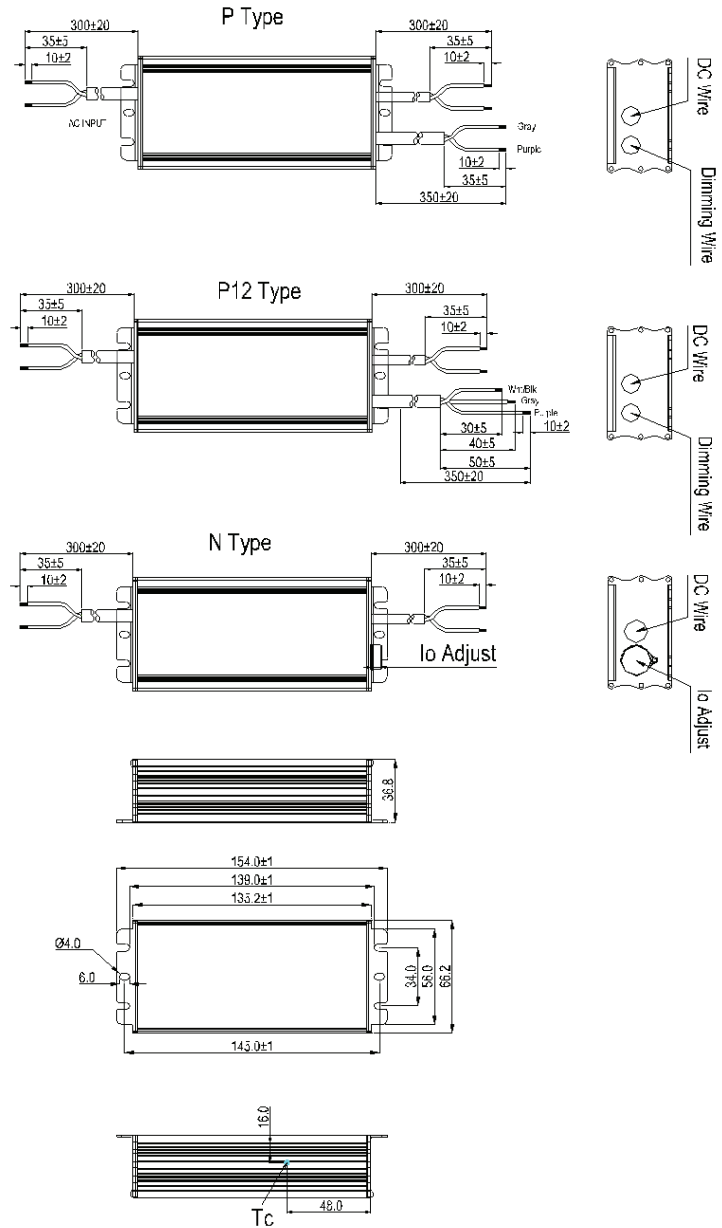

WIRE	SPECIFICATION	NOTE
Input	CCC+VDE H05RN-F 2*1.0mm <sup>2</sup> L=300mm	for CE
Output	18AWG*2C SJOW L=300mm	for CE
Dimming	22AWG*2C UL2733 L=350mm	for P
	22AWG*3C UL21996 L=350mm	for P12